

Product Name: **Gen V Raceport**
 Product Description: Gen V Raceport
 Product Number: TS-0204-113X
 Document Version: V1.00 Rev D



IMPORTANT NOTES ON YOUR GEN V RACEPORT

- Turbosmart accepts no responsibility whatsoever for incorrect installation of this product which is potentially hazardous and can cause serious engine damage or personal injury.
- The Gen V Raceport is designed for use with a turbocharger that do not have inbuilt BOV's or when a larger flow rate is required.
- Use only high-quality fittings ensuring maximum sealing reliability.

RECOMMENDATIONS

- **Allow for adequate cool airflow around the top diaphragm housing.**
- **DO NOT Mount the Raceport so that the top diaphragm housing is less than 100mm from a heat source.**
- **Fitting your Gen V Raceport may require fabrication or modification to your turbocharger piping. Turbosmart recommends that your Raceport is fitted by an appropriately qualified technician.**
- Turbosmart recommends that a boost gauge be permanently fitted to the vehicle.

KIT CONTENTS

Please check that the following items have been provided in your Gen V Raceport kit.

| Part | Description | Use |
|------|---------------------------|--|
| 1 | Turbosmart Gen V Raceport | Main unit |
| 2 | V-Band Clamp | V-Band Clamp |
| 3 | Weld Flange | Aluminium Weld Flange |
| 4 | O-Ring | Inlet Flange O-Ring seal |
| 5 | Fitting Kit | 1x 1/8" NPT nipple, 1x 1/8" NPT blanking plugs ** (1x pre-installed) ** |
| 6 | Turbosmart Sticker | Turbosmart sticker |

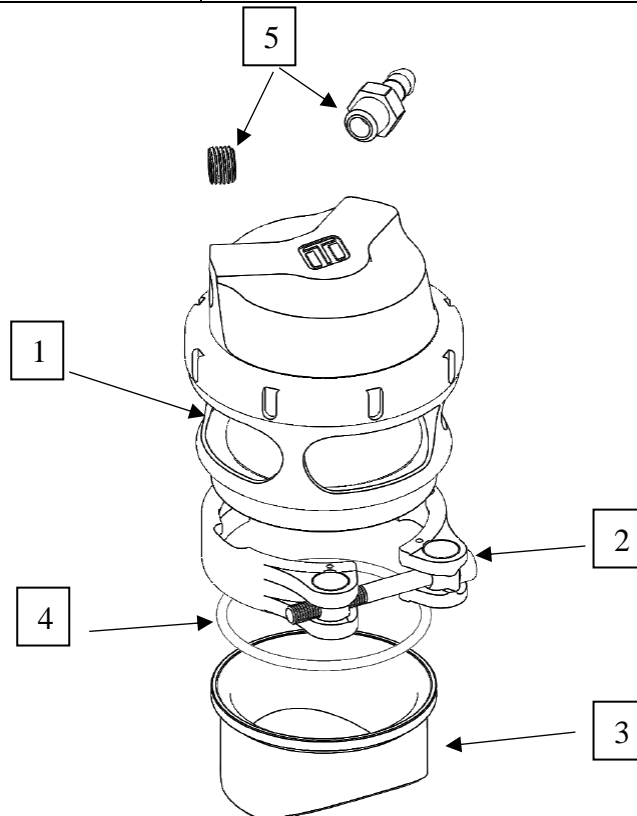

Figure 1 - Kit Contents

CONTENTS

| | |
|---|----|
| KIT CONTENTS..... | 1 |
| TOOLS REQUIRED | 2 |
| SUGGESTED SEALANTS..... | 2 |
| GEN V RACEPORT OVERVIEW | 3 |
| FITTING YOUR GEN V RACEPORT..... | 4 |
| HOW TO CHANGE YOUR GEN V RACEPORT SPRING | 5 |
| TUNING YOUR VACUUM LEVEL..... | 6 |
| HOW TO CHANGE YOUR GEN V RACEPORT DIAPHRAGM | 7 |
| TROUBLESHOOTING | 12 |

TOOLS REQUIRED

- Non-marking spanners to tighten fittings
- 4mm hex key
- 3/16" hex key
- Collar tool (TS-0505-3008)
- Flat Blade screwdriver

SUGGESTED SEALANTS

- Loctite 243 Thread locker
- Loctite 271 Thread locker
- Loctite 567 Thread Sealant

GEN V RACEPORT OVERVIEW

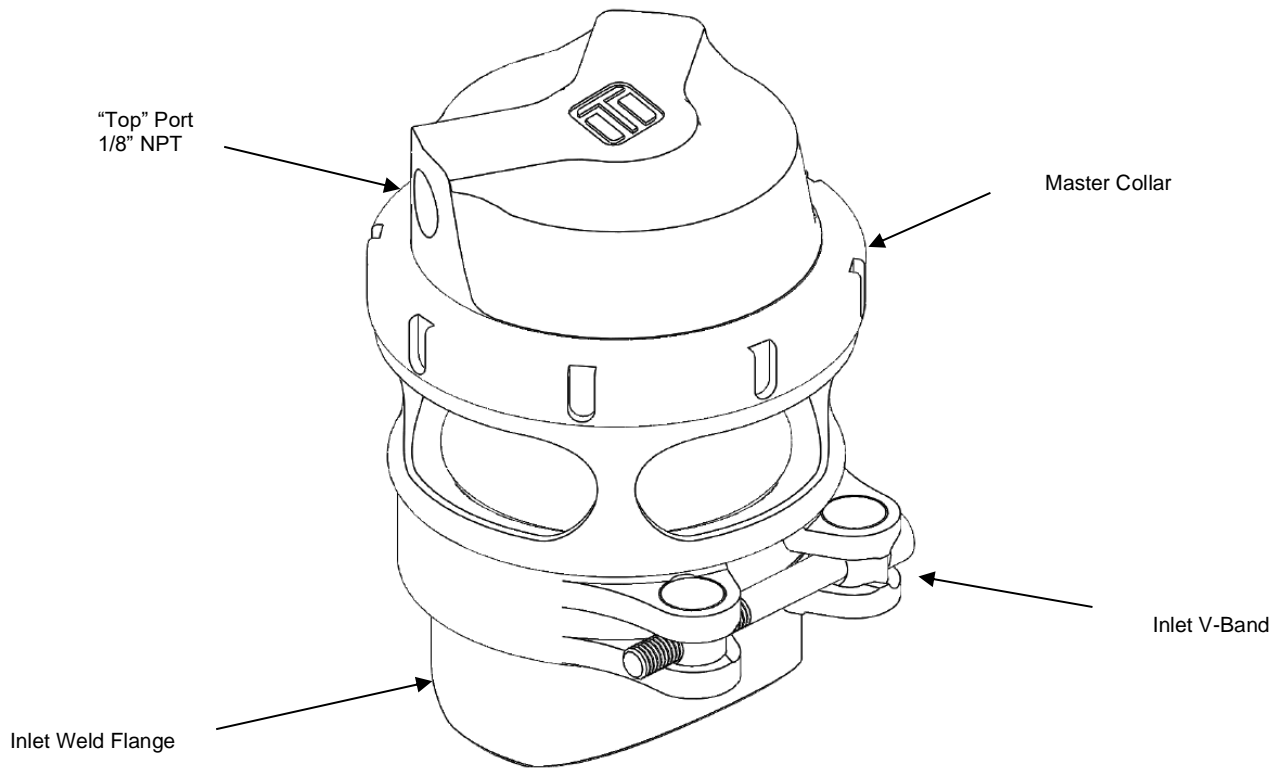

Figure 2 – Gen V Raceport Overview

FITTING YOUR GEN V RACEPORT

1 Mounting your New Turbosmart Gen V Raceport

The Gen V series of Raceport is a direct fit replacement for the Raceport and no modification is necessary provided packaging space is sufficient.

The weld flanges should be welded to your charge pipe in a suitable location. The weld flanges are compatible with aluminium welding rod material. Purge bungs should be used to maintain the straightness of the flange during the welding process. **TS-0204-3003**

For best results, an attempt should be made, if space allows, to mount the Gen V Raceport as close to the throttle as possible. The Raceport should be mounted such that it is not on the inside radius of any bend.

CAUTION!

Do not place the actuator cap near a significant heat source as this could shorten the life of the diaphragm.

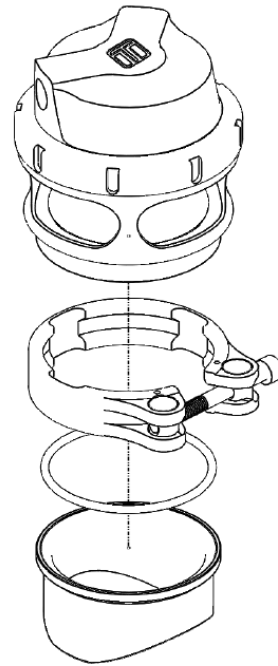

2 Fitting the Gen V Raceport

Prior to mounting the Gen V Raceport, place v-band over weld on flange by unscrewing the bolt on the v-band as far out as possible and then squeezing the bolt in a syringe motion to expand the v-band (squeeze the dots together below). Once the v-band is in its fully expanded position, slide the v-band over the flange to allow for the Raceport to be installed.

Do not forget to put the O-Ring seal into the flange before mounting the unit on the charge pipe. Using the 4mm hex bit socket and a torque wrench, Tighten the V-Band to 4N.m (3 ft/lbs). Ensure the Raceport is home correctly while torquing the bolt to not have a false torque as this will likely contribute to leaks.

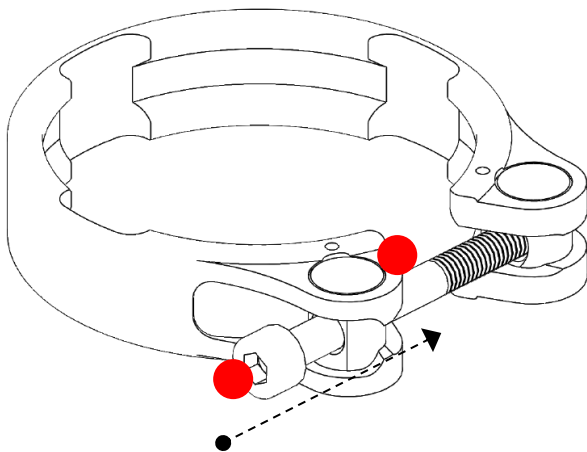

3 Fit Actuator Port Fittings

Fit top chamber port fittings prior to mounting the Raceport, install 1/8" NPT blank with 3/16" hex key and signal nipple into ports in the cap. Port order or orientation is not important, select which suits your packaging requirements. Apply thread lubricant and screw in clockwise until finger tight, then tighten further 1-2 turns for seal.

Select a suitable manifold pressure source, use the shortest possible hose length to the Raceport.

CAUTION!

Do not share manifold pressure source with fuel pressure regulator or any other critical instrument.

5 Start Engine and Check for Leaks

Congratulations, your Gen V Raceport is installed and ready for use. Double check all fittings, lines and mountings then proceed to start engine and check for leaks.

HOW TO CHANGE YOUR GEN V RACEPORT SPRING

The Gen V Raceport has a variety of springs to suit different Vacuum levels and applications. Turbosmart provides the Gen V Raceport pre-installed with 18InHg spring. Different spring combinations may be required to suit different application requirements and tuning.

1 Remove Raceport BOV From Charge Pipe

Remove manifold pressure source hose from the BOV. Unscrew V-band bolt in an anti-clockwise direction to the very end of the thread, squeeze the bolt against the V-band in a syringe like motion to expand the V-band over the flange. Remove Gen V Raceport being careful not to drop or lose the sealing O-Ring.

CAUTION!

Allow engine to cool down before removing your Gen V Raceport

2 Remove Top Cap

Prior to removing the Gen V Raceport cap, remove all fittings from the 1/8"NPT ports. Press down with light to medium load on the cap in a press or vice. Unscrew locking collar with a collar tool (TS-0505-3008) in an anti-clockwise direction until completely disengaged and gently remove tension from the press or vice allowing the spring to expand, finally remove cap when the spring has stopped expanding.

CAUTION!

Use soft jaws to prevent cosmetic damage.

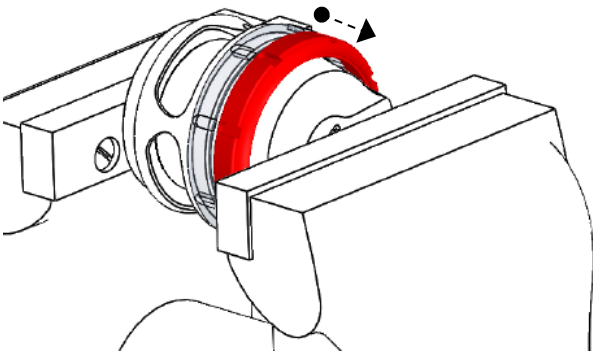

2 Remove Top Cap (cont.)

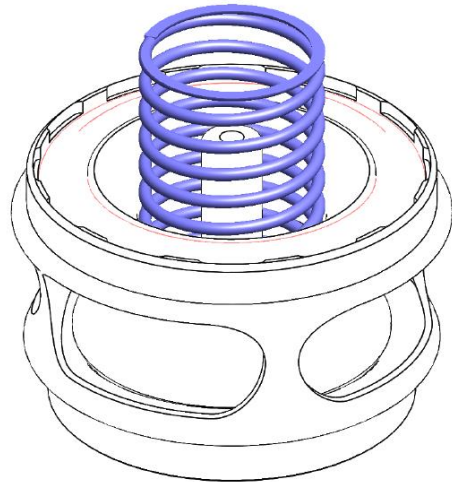
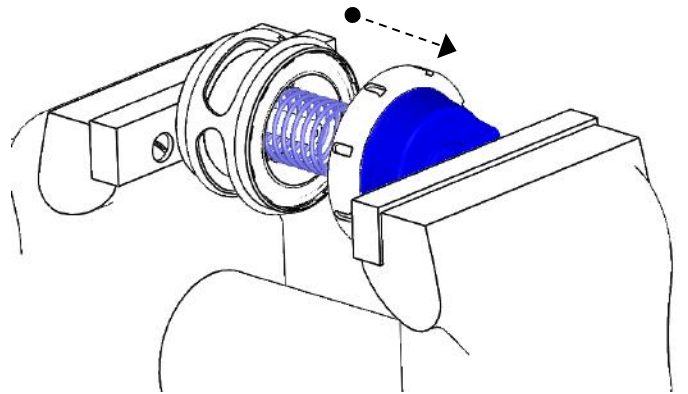

Configure Raceport with preferred spring combination.

3 Familiarise Yourself with Cap and Body Notches

Locate cap and body notches and grooves which dictate the alignment of the cap. These notches are used to locate the cap onto the body and must be aligned prior to compression of the cap onto the body.

CAUTION!

Ensure notches are aligned and seated home correctly prior to exerting force to tighten collar, permanent damage will occur if these are not aligned correctly.

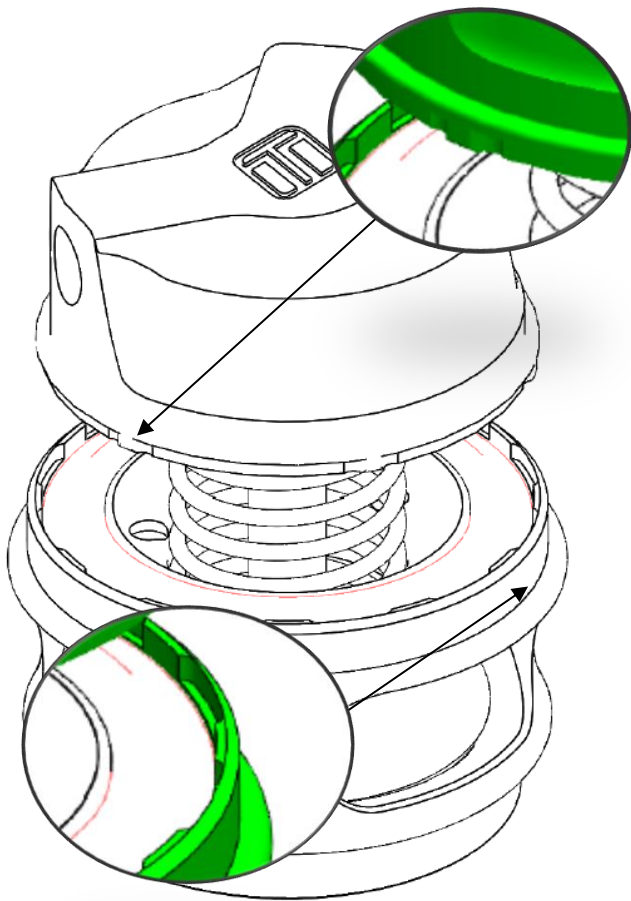

CAUTION!
Maintain downward pressure on cap while tightening collar or non-repairable thread damage will occur.

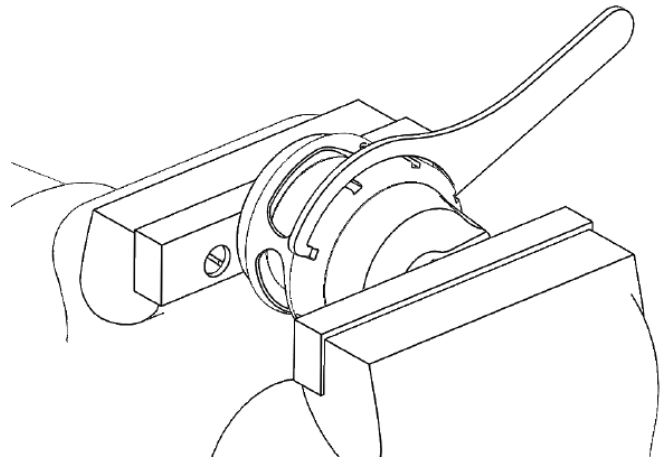

Reinstall fittings to the cap of the Raceport using fresh Loctite 567 thread sealant.

5 Reinstall Gen V Raceport

Place V-band over weld on flange by unscrewing the bolt on the V-band as far out as possible and then squeezing the bolt in a syringe motion to expand the V-band. Once the V-band is in its fully expanded position, slide the v-band over the flange to allow for the Raceport to be installed.

Do not forget to put the O-ring into the flange before mounting the unit on the Charge pipe. Using the 4mm hex bit socket and a torque wrench tighten the V-Band to **4N.m (3 ft/lbs)**.

4 Press Cap onto Body

Using a press or vice, compress the cap onto the body ensuring the notches are remaining aligned. Once the cap has seated home onto the body, screw the collar down by hand in a clockwise direction. While still in the press or vice, Tighten the collar further with the collar tool until the collar will not turn.

TUNING YOUR VACUUM LEVEL

The Race Port has a variety of springs to suit different vacuum levels. Different tuning levels and engine configurations produce different levels of idle vacuum. The Race Port is fitted with a standard spring which will remain closed until the engine produces more than 18 in/Hg. Turbosmart has a range of springs to suit different vacuum levels to ensure high levels of response from the Race Port.

IMPORTANT NOTES ON SETTING THE RACEPORT SPRING PRESSURE

A stiffer spring should only be used when necessary. The Gen V Raceport allows for different combinations of spring pressures. All springs that are adaptable with the Gen V Raceport are shown in the table below. The tuner can use combinations of up to 3 springs to achieve the following Manifold vacuum pressures. To aid in the identification of these springs they are supplied colour coded. Please see the following detailed instructions on setting your Gen V Raceport's spring pressure. The springs chosen should be rated to the lowest boost level desired.

See over for Spring Chart.

| | | | | | | |
|------------------------|-------------------|---------------------|---------------------|-----------------------|---------------------|---------------------|
| Manifold Vacuum | Location | Inner | Inner | Middle | Middle | Outer |
| | Colour | Pink | Orange | Purple | Green | Blue |
| | Part # | TS-0203-3002 | TS-0204-2105 | TS-0204-2104** | TS-0204-3105 | TS-0204-3102 |
| | Vacuum | 4 InHg | 7 InHg | 9 InHg | 15 InHg | 18 InHg |
| | 0-4 InHg | • | | | | |
| | 4-8 InHg | | • | | | |
| | 6-10 InHg | | | • | | |
| | 10-14 InHg | • | | • | | |
| | 11-15 InHg | | | | • | |
| | 14-18 InHg | | | | | • |
| | 15-19 InHg | • | | | • | |
| | 18-22 InHg | • | | | | • |
| | 19-23 InHg | | • | | • | |
| 22-26 InHg | | • | | | • | |

** Purple TS-0204-2104 only available in the spring kit
Table 1: Spring Chart

HOW TO CHANGE YOUR GEN V RACEPORT DIAPHRAGM

Gen V Raceport replacement diaphragm kit:

Piston Assembly: TS-0204-3103
Collar Tool: TS-0505-3008

CAUTION!

- Ensure diaphragm is contained within the groove prior to cap re-assembly.
- Pay attention not to rotate diaphragm.

CAUTION!

Allow engine to cool down before removing your Gen V Raceport

1 Remove Raceport BOV From Charge Pipe

Remove manifold pressure source hose from the BOV. Unscrew V-band bolt in an anti-clockwise direction to the very end of the thread, squeeze the bolt against the V-band in a syringe like motion to expand the V-band over the flange. Remove Gen V Raceport being careful not to drop or lose the sealing O-Ring.

CAUTION!

Allow engine to cool down before removing your Gen V Raceport

2 Remove Top Cap

Prior to removing the Gen V Raceport cap, remove all fittings from the 1/8"NPT ports. Press down with light to medium load on the cap in a press or vice. Unscrew locking collar with a collar tool (TS-05005-3008) in an anti-clockwise direction until completely disengaged and gently remove tension from the press or vice allowing the spring to expand, finally remove cap when the spring has stopped expanding.

CAUTION!

Use soft jaws to prevent cosmetic damage.

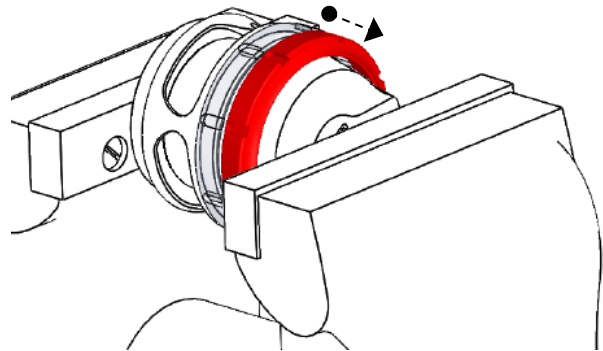

2 Remove Top Cap (cont.)

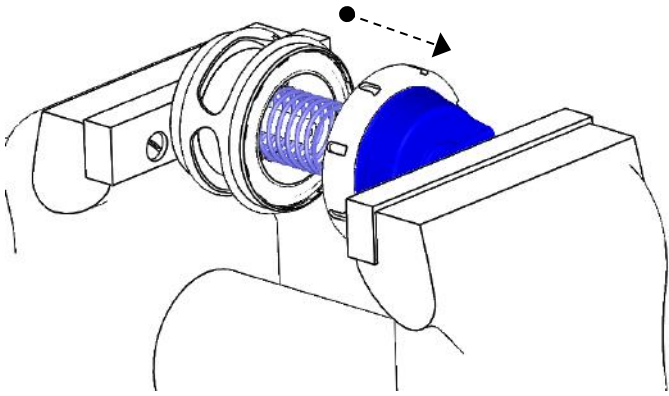

3 Change Piston Assembly

Lift the piston assembly out of the body of the Raceport, use a O-Ring pick to lift the bead of the diaphragm out of the groove if necessary. Clean all components removing all dirt and dust from the assembly.

Inspect for Damage before inserting new piston assembly into Raceport Body. Ensure Diaphragm bead is seated correctly in the groove on the body.

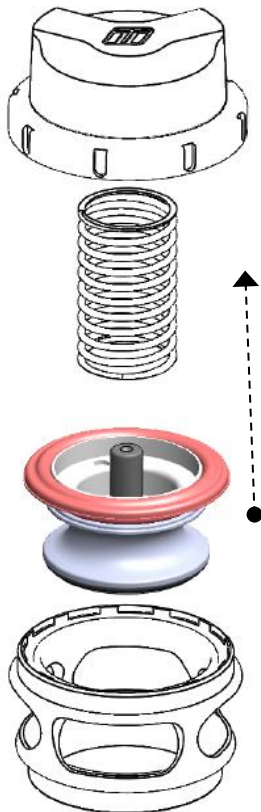

4 Change Piston Guide

The Raceport Piston replacement kit includes a new guide that is to be fitted to the cap, this guide is mandatory on early models of the GenV Raceport that use a smaller diameter stem on the piston.

This guide is held into the cap with Loctite and will require some effort to remove, Hold the cap in a way that does not distort or damage the cap in any way, use a friction wrench to undo the guide from the cap in and anticlockwise direction (standard Right-Hand thread). Clean any debris from the cap and replace with the new guide applying a small amount of red 271 thread locker to the threads.

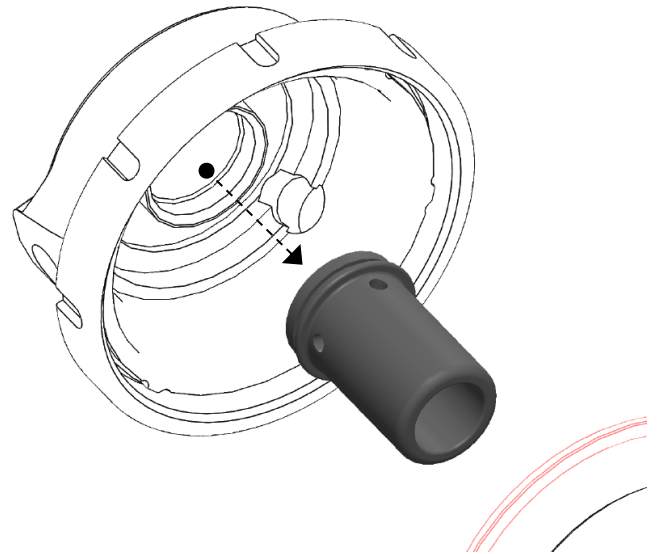

CAUTION!

Do NOT allow any thread locker to dry on the inside of the guide, this will result in the piston seizing.

5 Familiarise Yourself with Cap and Body Notches

Locate cap and body notches and grooves which dictate the alignment of the cap. These notches are used to locate the cap onto the body and must be aligned prior to compression of the cap onto the body.

CAUTION!

Ensure notches are aligned and seated home correctly prior to exerting force to tighten collar, permanent damage will occur if these are not aligned correctly.

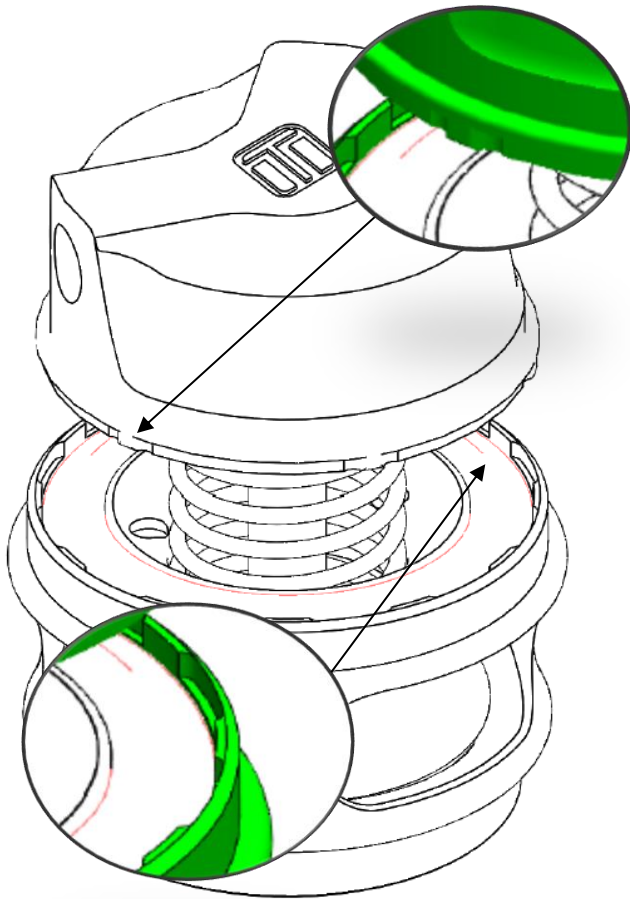

6 Press Cap onto Body

Using a press or vice, compress the cap onto the body ensuring the notches are remaining aligned. Once the cap has seated home onto the body, screw the collar down by hand in a clockwise direction. While still in the press or vice, Tighten the collar further with the collar tool until the collar will not turn.

Remove boost pressure source hose from the Raceport as well as the breather hose is fitted. Unscrew outlet V-Band nut in an anti-clockwise direction to the very end of the thread, Squeeze the nut against the V-Band in a syringe like motion to expand the V-band over the flange. Repeat for inlet V-Band. Remove Gen V Raceport being careful not to lose the valve seat. Mark the orientation of the valve to the body with tape or a paint pen.

HOW TO CONFIGURE SENSOR CAP VERSION

CAUTION!

- Applicable to Sensor Cap versions of GenV Race Port only.
- Cool air flow is required around the actuator to keep the sensor in its operating window.

CAUTION!

Allow engine to cool down before removing your Gen V Raceport

1 Remove Raceport BOV From Charge Pipe

Remove manifold pressure source hose from the BOV. Unscrew V-band bolt in an anti-clockwise direction to the very end of the thread, squeeze the bolt against the V-band in a syringe like motion to expand the V-band over the flange. Remove Gen V Raceport being careful not to drop or lose the sealing O-Ring.

CAUTION!

Allow engine to cool down before removing your Gen V Raceport

2 Remove Top Cap

Prior to removing the Gen V Raceport cap, remove all fittings from the 1/8"NPT ports. Press down with light to medium load on the cap in a press or vice. Unscrew locking collar with a collar tool (TS-05005-3008) in an anti-clockwise direction until completely disengaged and gently remove tension from the press or vice allowing the spring to expand, finally remove cap when the spring has stopped expanding.

CAUTION!

Use soft jaws to prevent cosmetic damage.

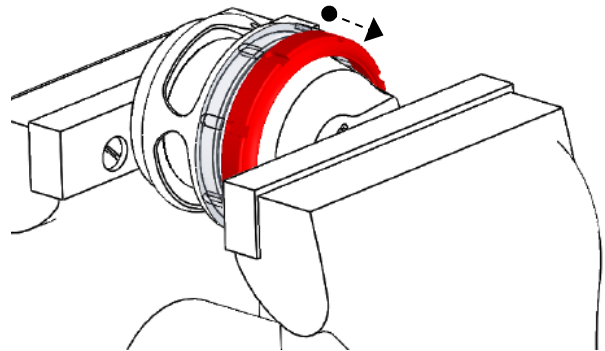

2 Remove Top Cap (cont.)

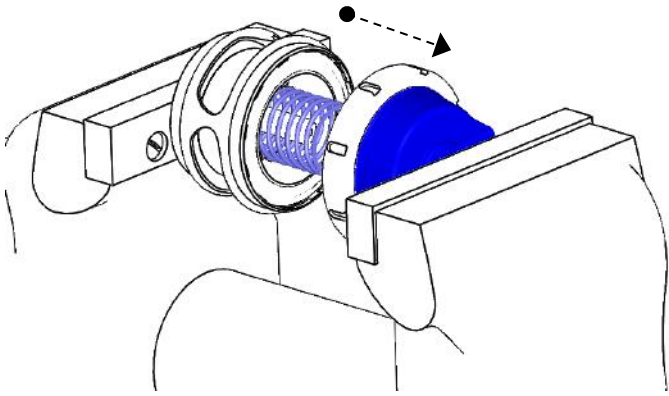

3 Install Magnet

Clean the top of the stem ensuring nothing will impede the installation of the magnet. Fit the magnet into the top of the stem with the marking facing out of the stem ensuring the magnet is placed all the way in.

Apply 243 thread locker to the locking screw provided and screw down with a flat blade screwdriver until firm against the magnet.

CAUTION!
Excessive force may damage the magnet or threads.

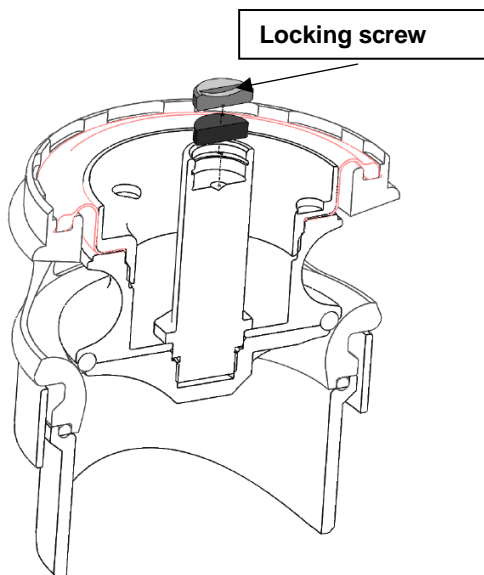

Inspect for Damage before inserting piston assembly into Raceport Body. Ensure Diaphragm bead is seated correctly in the groove on the body.

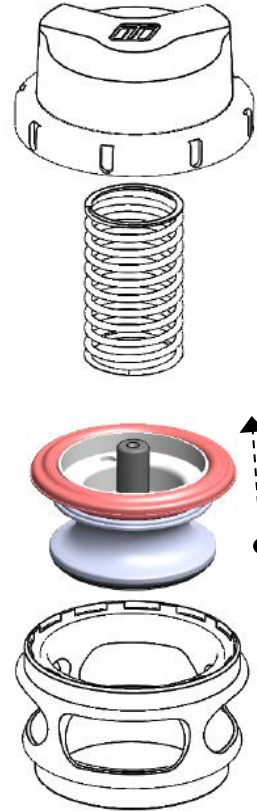

4 Familiarise Yourself with Cap and Body Notches

Locate cap and body notches and grooves which dictate the alignment of the cap. These notches are used to locate the cap onto the body and must be aligned prior to compression of the cap onto the body.

CAUTION!
Ensure notches are aligned and seated home correctly prior to exerting force to tighten collar, permanent damage will occur if these are not aligned correctly.

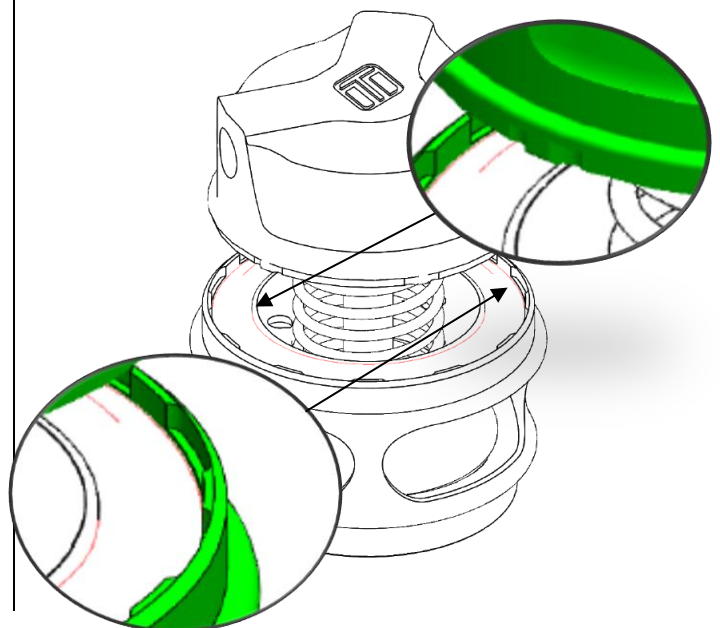

5 Press Cap onto Body

Using a press or vice, compress the cap onto the body ensuring the notches are remaining aligned. Once the cap has seated home onto the body, screw the collar down by hand in a clockwise direction. While still in the press or vice, Tighten the collar further with the collar tool until the collar will not turn.

Remove boost pressure source hose from the Raceport as well as the breather hose is fitted. Unscrew outlet V-Band nut in an anti-clockwise direction to the very end of the thread, Squeeze the nut against the V-Band in a syringe like motion to expand the V-band over the flange. Repeat for inlet V-Band. Remove Gen V Raceport being careful not to lose the valve seat. Mark the orientation of the valve to the body with tape or a paint pen.

6 Wiring

Your new Turbosmart sensor cap required installation of the sensor into the cap, apply a small amount of 243 Loctite to the threads of the sensor housing and screw into the cap of the Raceport by hand. If and grabbing is felt stop and try again ensuring the sensor is properly seated within the housing. The Sensor is supplied with unterminated wires for you to fit the connector of your choice.

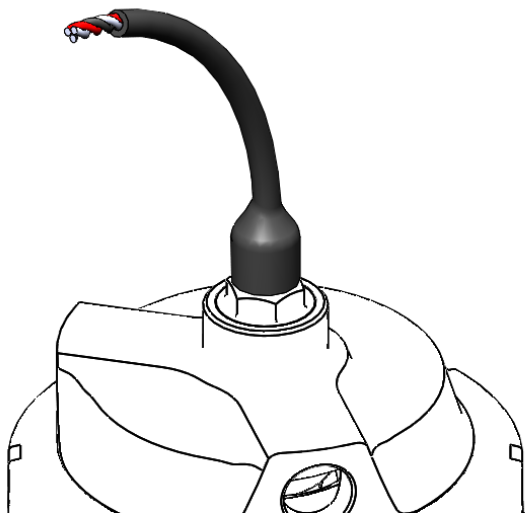

| Wire | Note | Rating |
|-------|-----------------------------|------------------|
| Red | Sensor Supply (V_{sup}) | 4.5-5.5 V_{dc} |
| Black | Sensor Ground (V_0) | 0V |
| White | Sensor Output (V_{out}) | 0- V_{supply} |

Connect the wires to your data logger accordingly. Use a high-quality connection to reduce noise and calibration fluctuation.

Ensure that the wiring is properly shielded from external heat sources.

CAUTION!

To ensure longevity from the sensor, ensure adequate airflow is supplied directly to the sensor to avoid overheating or sensor failure.

Turbosmart HE sensor has an operation temperature window of -40°C up to 170°C (340°F) junction temperature, for temperatures outside of this window the V_{out} will revert to less than 2.5V

Temperature exposure above 260°C (500°F) can cause permanent damage to the sensor.

7 Calibration*

Insert the relevant calibration curve into your data logger for the product family you have.

WG38/40 (all configurations)

| Valve Lift (mm) | V_{out} |
|-----------------|-----------|
| -0.75 | 2.35 |
| 0 | 2.313 |
| 2 | 2.236 |
| 4 | 2.174 |
| 6 | 2.075 |
| 8 | 1.946 |
| 10 | 1.731 |
| 12 | 1.444 |
| 14 | 0.977 |
| 16 | 0.712 |

CAUTION!

Ensure magnet is installed in the correct direction if V_{out} is more than 2.5V

NOTE! For best results, each raceport should be calibrated to your setup.

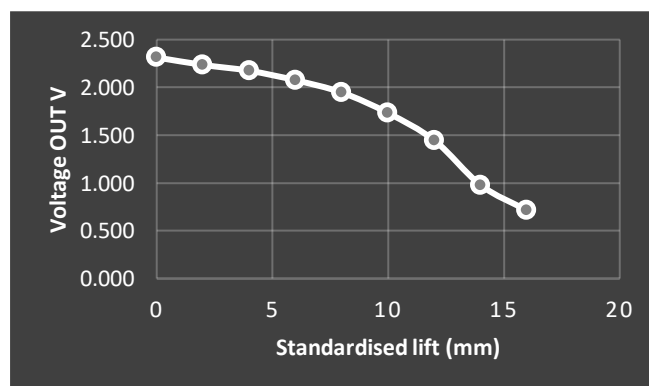

TROUBLESHOOTING

- Check the vacuum hose for splits, cracks, loose connection, kinking or any obstruction – old or fatigued hose may collapse under vacuum causing an obstruction.
 - With the engine running remove the vacuum / pressure hose from the nipple in the cap of the Race Port, there should a loud hissing sound. The engine should idle poorly, double check by covering the end of the hose with your finger. If this does not occur, the hose could be blocked or crimped. Check the hose and replace if necessary.
 - Ensure that the vacuum / pressure source is not shared and that the vacuum source is directly from the inlet manifold.
 - Check the seal between the adapter and the Race Port – ensure that there is no gap between the Race Port base and the weld flange.
 - Check the join between the adapter and the intercooler pipe for leaking.
 - Ensure that the right spring is installed in the Race Port for your engine's vacuum level.
 - Failing the above, submit a technical request to tech@turbosmart.com.au with information of your engine configuration and photos of installation.
 -
-